

SAE Technical Standards Board Rules provide that: "This report is published by SAE to advance the state of technical and engineering sciences. The use of this report is entirely voluntary, and its applicability and suitability for any particular use, including any patent infringement arising therefrom, is the sole responsibility of the user." SAE reviews each technical report at least every five years at which time it may be revised, reaffirmed, stabilized, or cancelled. SAE invites your written comments and suggestions.

**REV.
D**

SAE AS9219

FEDERAL SUPPLY CLASS
5306

RATIONALE

THIS DOCUMENT HAS BEEN DETERMINED TO CONTAIN BASIC AND STABLE TECHNOLOGY WHICH IS NOT DYNAMIC IN NATURE.

STABILIZED NOTICE

THIS DOCUMENT HAS BEEN DECLARED "STABILIZED" BY THE SAE E-25 GENERAL STANDARDS FOR AEROSPACE AND PROPULSION SYSTEMS COMMITTEE AND WILL NO LONGER BE SUBJECTED TO PERIODIC REVIEWS FOR CURRENCY. USERS ARE RESPONSIBLE FOR VERIFYING REFERENCES AND CONTINUED SUITABILITY OF TECHNICAL REQUIREMENTS. NEWER TECHNOLOGY MAY EXIST.

SAE values your input. To provide feedback on this Technical Report, please visit <http://www.sae.org/technical/standards/AS9219D>

THIRD ANGLE PROJECTION

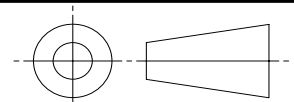

CUSTODIAN: E-25

PROCUREMENT SPECIFICATION: AS7459

SAE Aerospace
An SAE International Group

AEROSPACE STANDARD

BOLT, MACHINE - STEEL, DIFFUSED NICKEL-CADMIUM PLATED, DOUBLE HEXAGON EXTENDED WASHER HEAD, DRILLED, UNS K14675, 195 KSI MIN, .3125-24 UNJF-3A

SAE AS9219

**REV.
D**

ISSUED 2000-08 REVISED 2011-11 STABILIZED 2012-10

Copyright 2012 SAE International

All rights reserved. No part of this publication may be reproduced, stored in a retrieval system or transmitted, in any form or by any means, electronic, mechanical, photocopying, recording, or otherwise, without the prior written permission of SAE.

TO PLACE A DOCUMENT ORDER: Tel: 877-606-7323 (inside USA and Canada) Fax: 724-776-0790

Tel: +1 724-776-4970 (outside USA) Email: CustomerService@sae.org

SAE WEB ADDRESS: <http://www.sae.org>

NOTICE

THE INITIAL SAE PUBLICATION OF THIS DOCUMENT WAS TAKEN DIRECTLY FROM U.S. MILITARY STANDARD MS9219, NOTICE 1. THIS SAE STANDARD RETAINS THE SAME PART NUMBERS ESTABLISHED BY THE ORIGINAL MILITARY DOCUMENT.

ANY REQUIREMENTS ASSOCIATED WITH QUALIFIED PRODUCTS LISTS (QPL) MAY CONTINUE TO BE MANDATORY FOR DOD CONTRACTS. REQUIREMENTS RELATING TO QPL'S HAVE NOT BEEN ADOPTED BY THE SAE FOR THIS STANDARD AND ARE NOT PART OF THIS SAE DOCUMENT.

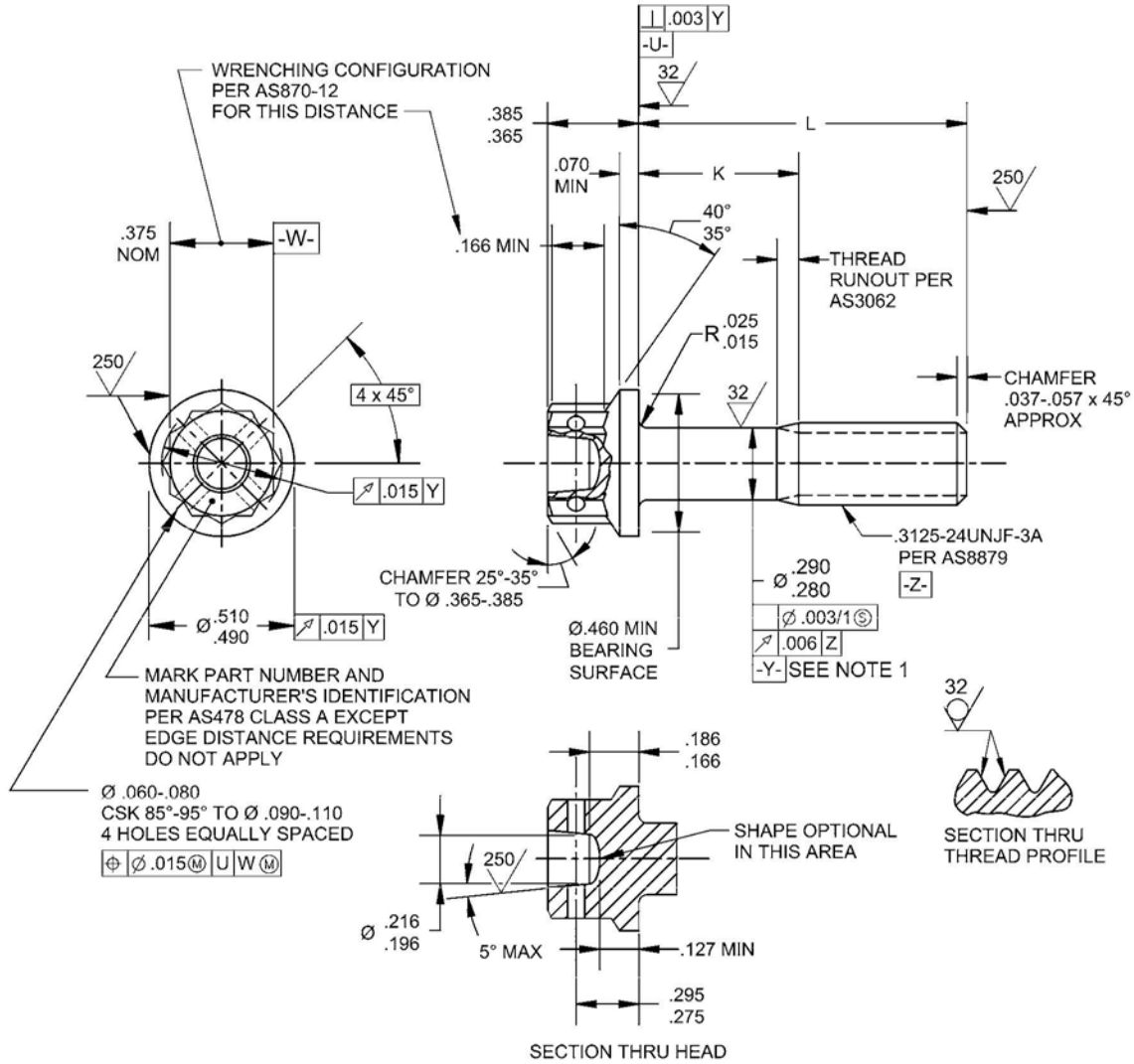



FIGURE 1 - BOLT

 <p>SAE Aerospace An SAE International Group</p>	<p>AEROSPACE STANDARD</p> <p>BOLT, MACHINE - STEEL, DIFFUSED NICKEL-CADMIUM PLATED, DOUBLE HEXAGON EXTENDED WASHER HEAD, DRILLED, UNS K14675, 195 KSI MIN, .3125-24 UNJF-3A</p>	<p>SAE AS9219</p> <p>SHEET 1 OF 3</p>	<p>REV. D</p>
---	--	--	----------------------